

# 134 JENKINS RD

**Location** 134 JENKINS RD

**Mblu** 39/ 98/ 52/ /

**Acct#**

**Owner** CARR PAUL H &

**Assessment** \$742,900

**PID** 100335

**Building Count** 1

**topoTopography** Rolling

**Utility** Well, Septic

## Current Value

Assessment					
Valuation Year	Building	Extra Features	Outbuildings	Land	Total
2023	\$494,200	\$2,300	\$0	\$246,400	\$742,900

## Owner of Record

**Owner** CARR PAUL H &  
KILPACK VIRGINIA  
**Address** 134 JENKINS RD  
BEDFORD, NH 03110

**Sale Price** \$397,500  
**Certificate**  
**Book & Page** 8623/2139  
**Sale Date** 11/25/2013  
**Instrument** 00  
**Qualified** Q

## Ownership History

Ownership History						
Owner	Sale Price	Certificate	Book & Page	Instrument	Sale Date	
CARR PAUL H &	\$397,500		8623/2139	00	11/25/2013	
BONNETTE PETER M &	\$0		8166/2184	1F	12/30/2009	
GILHAM LISA	\$425,000		7512/0896	00	07/29/2005	
HAGOPIAN ROBERT G & ELLEN R	\$338,300		6512/2061	00	10/30/2001	
STABILE HOMES AT BEDFORD INC	\$840,000		6259/0990	1N	06/30/2000	

## Building Information

### Building 1 : Section 1

**Year Built:** 2001  
**Living Area:** 2,382

Replacement Cost: \$617,705

Building Percent Good: 80

Replacement Cost

Less Depreciation: \$494,200

**Building Attributes**

Field	Description
Style:	Ranch
Model	Residential
Grade:	Good +30
Stories:	1 Story
Occupancy	1
Exterior Wall 1	Vinyl Siding
Exterior Wall 2	
Roof Structure:	Gable/Hip
Roof Cover	Asph/F Gls/Cmp
Interior Wall 1	Drywall/Sheet
Interior Wall 2	
Interior Flr 1	Hardwood
Interior Flr 2	
Heat Fuel	Gas
Heat Type:	Forced Air-Duc
AC Type:	Central
Total Bedrooms:	2 Bedrooms
Total Bthrms:	3
Total Half Baths:	0
Total Xtra Fixtrs:	
Total Rooms:	6
Bath Style:	Average
Kitchen Style:	Average
Num Kitchens	01
Cndtn	
Num Park	
Fireplaces	
Fndtn Cndtn	
Basement	

**Building Photo**



(https://images.vgsi.com/photos/BedfordNHPhotos/A00\01\20\06.jpg)

**Building Layout**

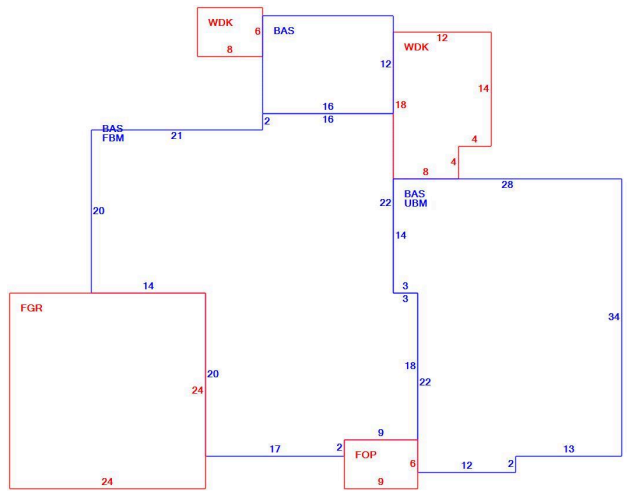

(ParcelSketch.ashx?pid=100335&bid=100367)

Building Sub-Areas (sq ft)			<u>Legend</u>
Code	Description	Gross Area	Living Area
BAS	First Floor	2,382	2,382
FBM	Basement, Finished	1,274	0
FGR	Garage, Framed	576	0
FOP	Porch, Open	54	0
UBM	Basement, Unfinished	916	0
WDK	Deck, Wood	248	0
		5,450	2,382

**Extra Features**

Extra Features					<u>Legend</u>
Code	Description	Size	Value	Assessed Value	Bldg #
FPL	FIREPLACE	1.00 UNITS	\$1,100	\$1,100	1
SS	SHOWER STALL	1.00 UNITS	\$1,200	\$1,200	1

**Land**

**Land Use**

**Use Code** 1010  
**Description** SINGLE FAM MDL-01  
**Zone** RA  
**Neighborhood** 80  
**Alt Land Appr** No  
**Category**

**Land Line Valuation**

**Size (Acres)** 1.42  
**Frontage**  
**Depth**  
**Assessed Value** \$246,400

**Outbuildings**

<b>Outbuildings</b>	<u><b>Legend</b></u>
No Data for Outbuildings	

**Valuation History**

<b>Assessment</b>					
<b>Valuation Year</b>	<b>Building</b>	<b>Extra Features</b>	<b>Outbuildings</b>	<b>Land</b>	<b>Total</b>
2023	\$494,200	\$2,300	\$0	\$246,400	\$742,900
2022	\$429,400	\$2,300	\$0	\$182,400	\$614,100
2021	\$429,400	\$2,300	\$0	\$182,400	\$614,100